

High Spin Industrial Washer Extractors LH 60, LH 75, LH 95

FEATURES

- Freestanding, high spin
- Front and top panels from stainless steel
- Stainless steel drum and tub
- Standard Easy to use (EC) microprocessor
- Large drain valve (Ø76 mm)
- Easy access to all parts
- Patented soap hopper and drain valve (Liqui-Mix® system)
- Standard liquid soap connections
- Compact width: 660 mm, ideal for replacing existing models (including models of most competitors)
- Frequency controlled motor
- PowerWash® perforated lifting ribs: more mechanical action, lower water consumption

OPTIONS

- Stainless steel cabinet (AISI 304)
- Graphitronic® - new graphic display with almost unlimited possibilities as:
 - Communication interface enabling remote service
 - Multilingual microprocessor
 - Freely programmable
- Coin operated timer
- Liquid soap pumps
- SoftWash® version (wet cleaning)
- Water recovery kit
- Trace-Tech® traceability software and networking system



TYPE		LH 60	LH 75	LH 95
CAPACITY				
Drum volume	l	60	73	95
Capacity	kg/lb	6 /15	7 /18	10/25
Drum diameter	mm	Ø530	Ø530	Ø530
DRUM SPEED				
Wash speed	rpm	48	48	48
Spin speed	rpm	1000	1000	1000
G-factor		300	300	300
PROGRAMMER				
Coin meter (or tokens)			+	
Coin counter			+	
EC microprocessor			standard	
Graphitronic® microprocessor			+	
CABINET				
Coloured panels			standard	
Stainless steel AISI 304			+	
CONNECTION				
		Freestanding		
HEATING				
100% hot water	°C	90	90	90
	°F	194	194	194
100% electrical	kW	6-9	6-9-12	6-9-12
Steam additional heating	bar	1-3	1-3	1-3
Steam high pressure	bar	3-8	3-8	3-8
CONNECTION				
Electrical		1×220-240V 50/60Hz 3×220-240V 50Hz 3×380-415V+N 50/60Hz Others on request		
Water inlet	inch	3/4"		
Steam inlet	inch	1/2"		
DIMENSIONS				
HxWxD	mm	1080×660×770	1080×660×770	1140×660×865
TRANSPORT DATA				
Gross weight				
Cardboard packing	kg	240	250	300
Net weight	kg	230	235	275
Volume (packed)				
Cardboard packing	m ³	0,79	0,79	0,92
Cardboard packing HxWxD	mm	1250×750×850	1250×750×850	1300×750×950

+ = Available
Standard = Standard execution

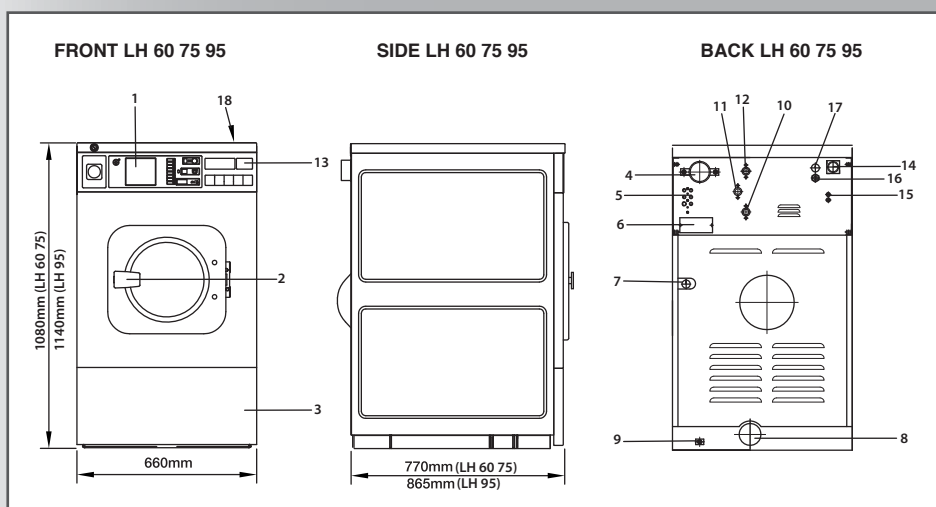

1. Electronic programmer
2. Door handle
3. Servis panel
4. Air ventilation
5. Liquid soap hose connection
6. Name plate
7. Steam connection
8. Drain outlet
9. Electrical connection to liquid soap
10. Warm water connection
11. Cold soft water connection
12. Cold hard water connection
13. Control panel
14. Main switch
15. Fuses
16. Main power supply
17. Power supply to liquid soap pumps
18. Soap hoppers

Lavamac preserves the right to change the machines and the specification in this leaflet at any time, without prior notice. Details and photographs are only for information and never binding.

www.lavamac.eu



06-2009/532441