

industrial laundry equipment

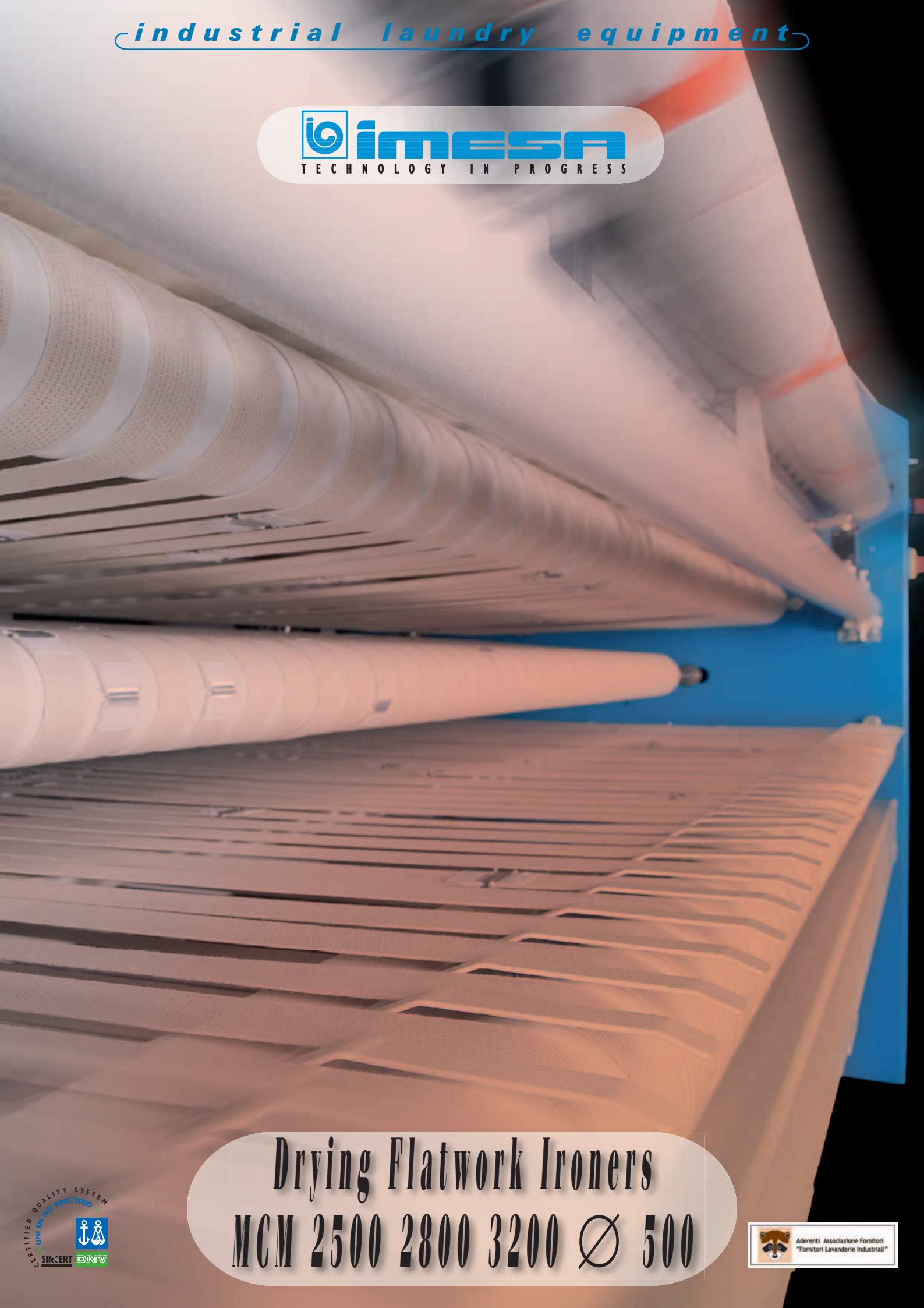

Drying Flatwork Ironers
MCM 2500 2800 3200 Ø 500

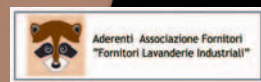



INVEST AND SAVE!

Saving in energy, time and labour:

IMESA MCM Ø 500 range is the right answer to the modern laundry request.

The ironer high productivity is granted by:

- The special configuration of the ironing belt that is avoiding the ironing defects: belts conjunction signs and signs of separation between the belts.
- A special heating / suction system that assures an omogenous and regular heating on all the ironing roller length.

The user can choose to use all the ironing length or dividing the working space in two areas completely independent.

In this second case the user could choose for each line which kind of folding program select: no folding, single or double fold.



Available only on folding system version

The ironer is equipped with a big **TOUCH SCREEN** that anale the user to select easily and quickly the most suitable ironing program.



The ironers without folding system are equipped with an electronic panel that control:

- Start and stop
- Celsius and Fahrenheit temperature electronic control
- Electronic speed in meter per minute
- Cool down
- Suction
- Count down



MCM 2500 280

TECHNOLOGY

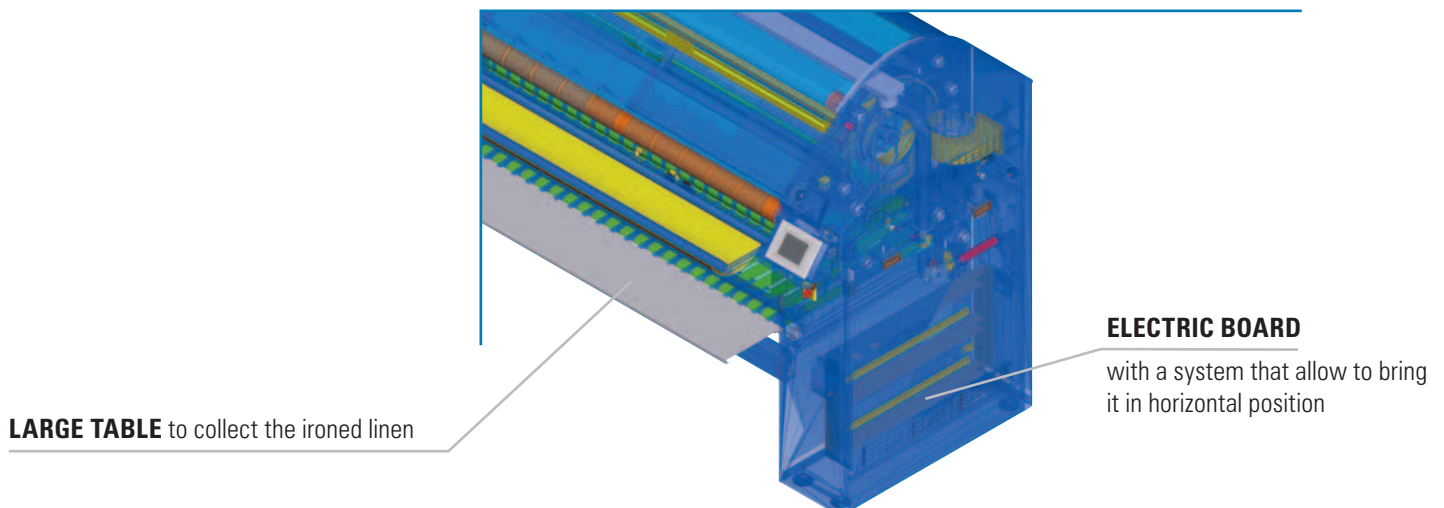
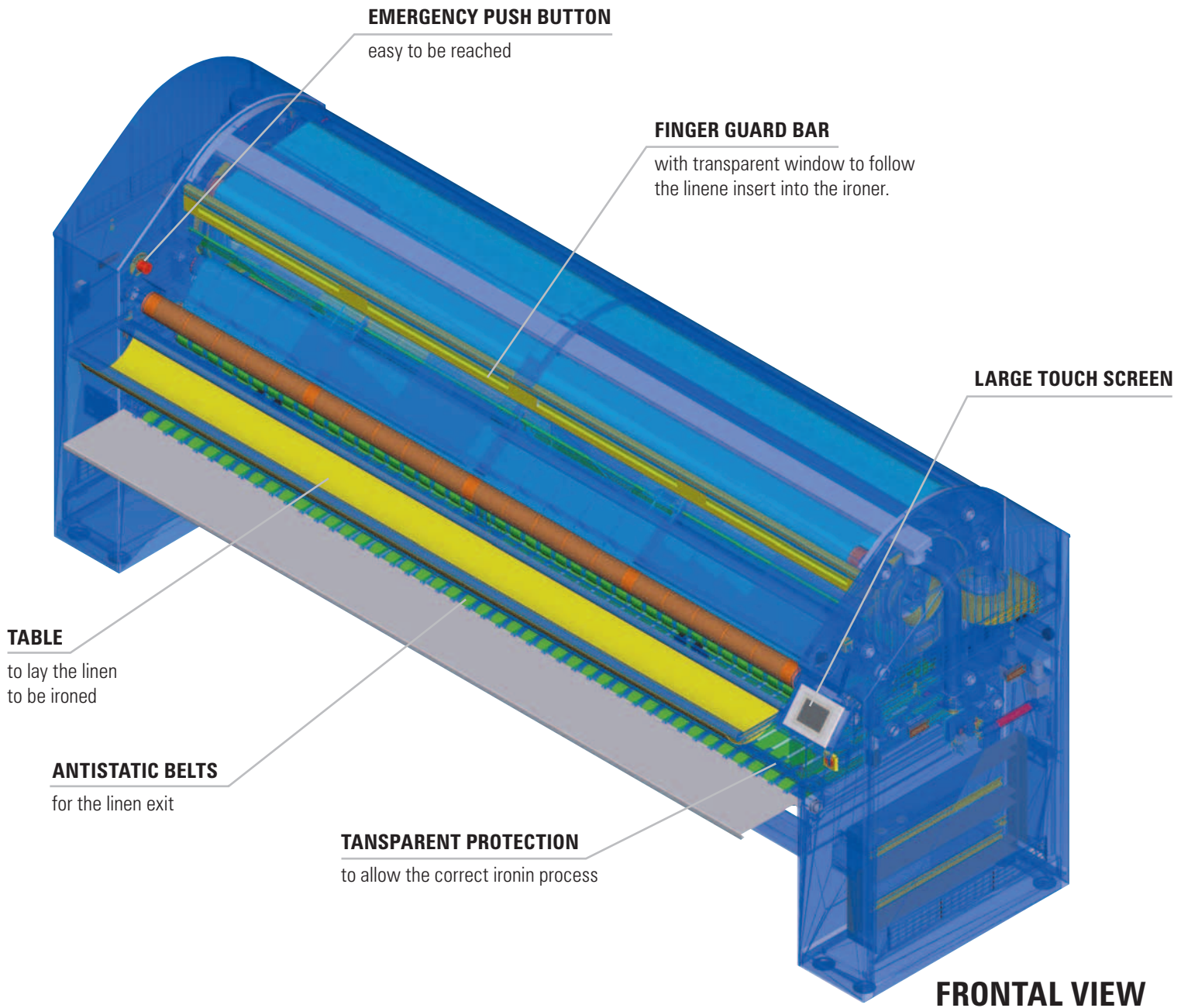

00 3200 Ø 500

BY YOUR SIDE

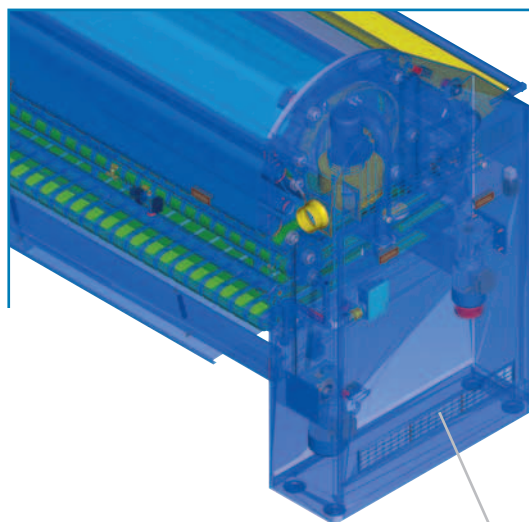

INLET AIR FILTER

to avoid the fluff
inside the mechanism

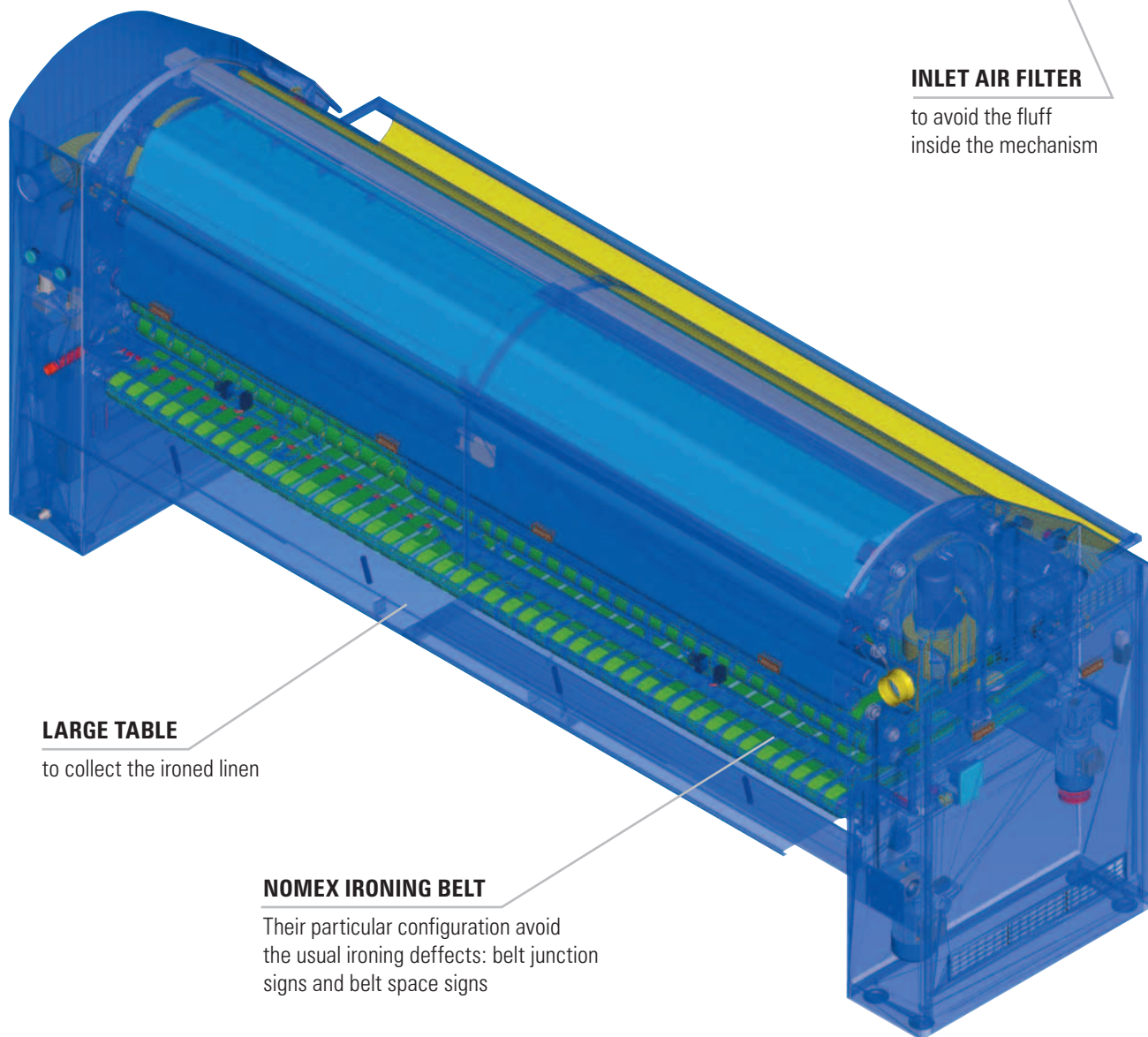

LARGE TABLE

to collect the ironed linen

NOMEX IRONING BELT

Their particular configuration avoid
the usual ironing defects: belt junction
signs and belt space signs

REAR VIEW

SOLUTIONS AT YOUR DISPOSAL

IMESA has always paid attention to the individuality of the customer: the big touch screen enable the operator to control and set the ironing speed (from 1 to 9m/minute), the temperature (up to 180°C) and to configure the folding program; using this three parameters the user can composed up to 128 ironing programs!

The linen ironed and folded can be collected on the frontal or rear table.

IMESA drying ironers are projected with a strong frame based on design research, taking care to all the particulars in order to give the most suitable service from all the point of view.

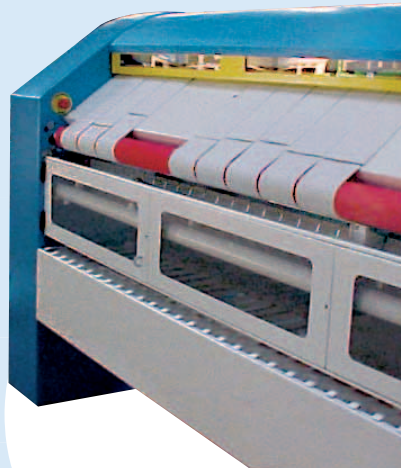

When the table is not used it can be folded on the machine side with a simple pressure, thanks to an aerodynamic system.



The linen, laid on the apposite table, can be easily introduced into the ironer and, thanks to the window on the finger guard bar, the operator can follow the correct process: **IMESA** thought both to the operator safe and to the necessity to follow the correct linen introduction system.

Thanks the protection with window the user can follow the correct ironing and folding process easily and without any danger!



MCM
2500 2800 3200 Ø 500

To make easier the maintenance service, the access to the mechanisms is very easy.

The electric board can be brought in horizontal position to make easier the technician operation.

